

Lie-Nielsen Holdfast Hole Layout

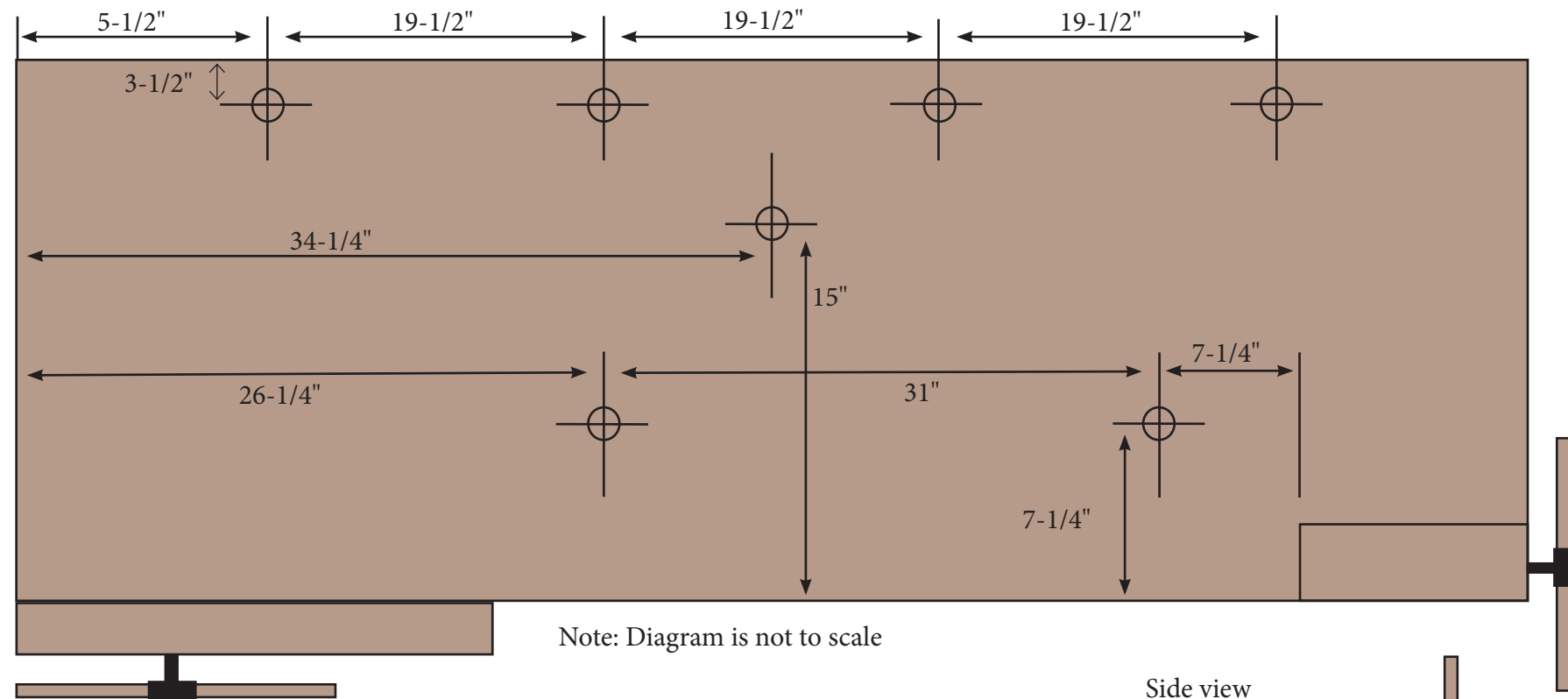

Note: Diagram is not to scale

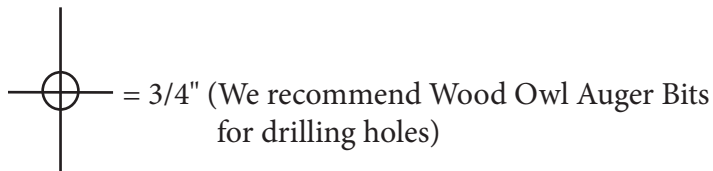
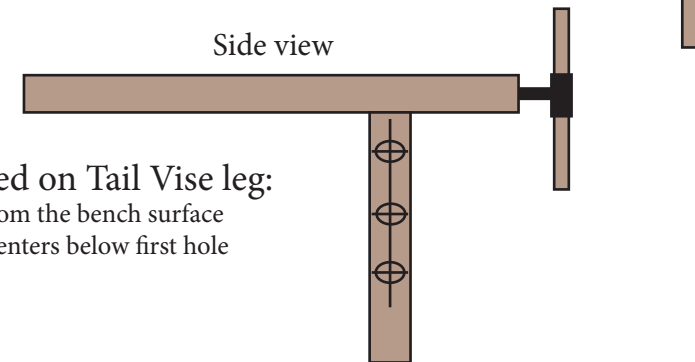

Three holes centered on Tail Vise leg:

First Hole: $8\frac{1}{4}$ " down from the bench surface
 Holes 2 and 3: on $6\frac{1}{2}$ " centers below first hole

Note:

- The Holdfast holes along the backside of the bench are intended to hold battens for planing stops. They line up offset from a dog hole on the front.
- The middle hole is intended for clamping a shooting board or bench hook.
- The front holes are spaced to hold our Dovetail Vise or clamp stock for chopping dovetails or mortises.
- Add more holes if needed.