

Lie-Nielsen
TOOLWORKS[®]
INC.

CHAIN DRIVE VISE

INSTALLATION INSTRUCTIONS

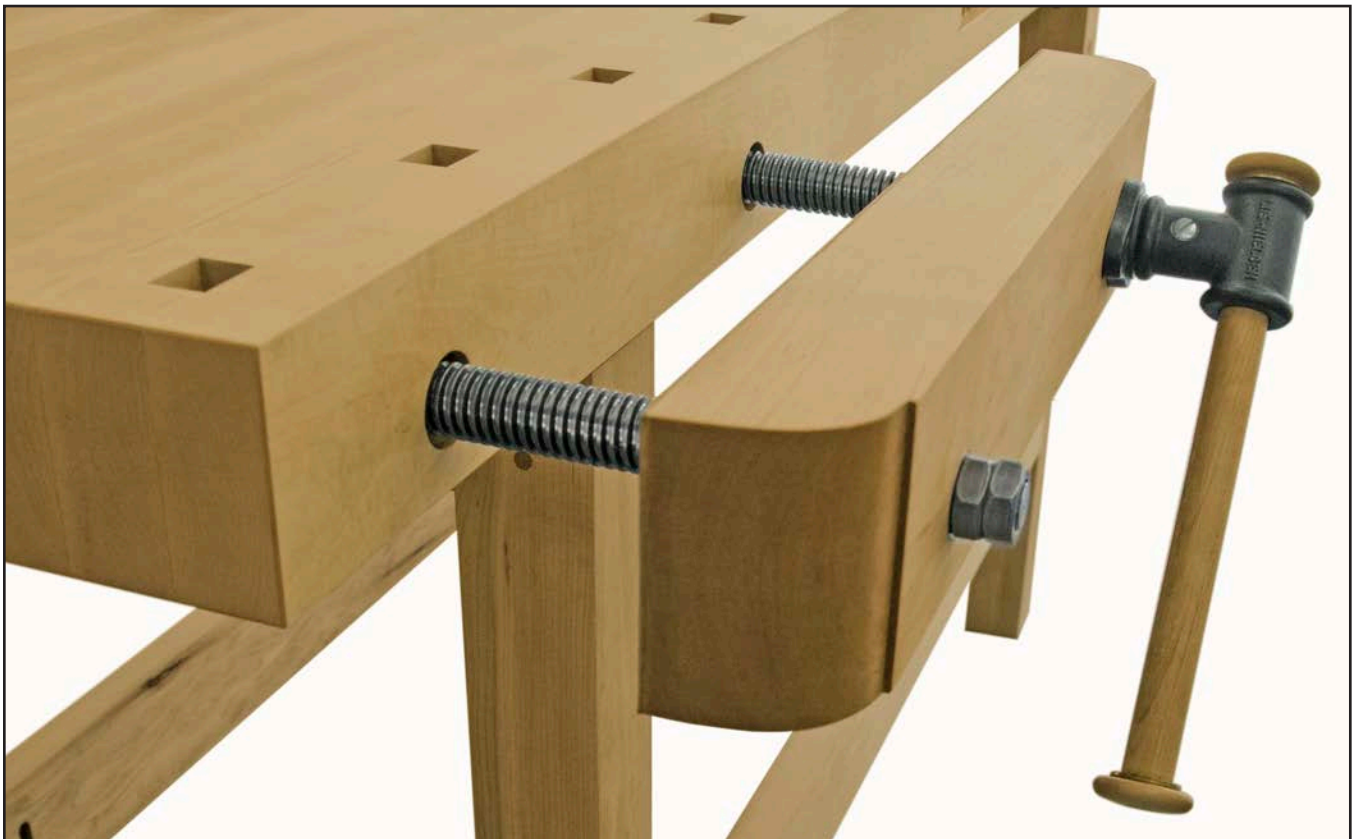

(revised 1/25/2019)

LIE-NIELSEN CHAIN DRIVE VISE INSTRUCTIONS

TABLE OF CONTENTS

	PAGE
ABOUT YOUR CHAIN DRIVE VISE	3
PARTS LIST	4
EXPLODED PARTS DIAGRAM	5
STEP 1. PREPARE YOUR BENCH TOP	6
STEP 2. PREPARE YOUR VISE JAW	7-8
STEP 3. INSTALL VISE JAW & SCREW HARDWARE	9-10
STEP 4. INSTALL T-HANDLE ASSEMBLY	11
STEP 5. MOUNTING STANDOFFS	12-13
DIAGRAM 1. EXPLODED VISE HARDWARE DIAGRAM	5
DIAGRAM 1A. BENCH TOP SPECIFICATIONS	6
DIAGRAM 1B. POCKET DEPTH SPECIFICATIONS	6
DIAGRAM 2A. VISE JAW HALF NO. 1: CUTS & MEASUREMENTS	7
DIAGRAM 2B. VISE JAW HALF NO. 2: CUTS & MEASUREMENTS	7
DIAGRAM 2C. VISE JAW: VISE SCREW HOLE SPECIFICATIONS	8
DIAGRAM 2D. COUNTERBORE SPECIFICATIONS	8
DIAGRAM 3A. EXPLODED VISE SCREW HARDWARE DIAGRAM	9

QUESTIONS?

CONTACT US AT 800-327-2520 • TOOLWORKS@LIE-NIELSEN.COM

ABOUT YOUR CHAIN DRIVE VISE

The Lie-Nielsen Chain Drive Vise combines simplicity of design and function with heavy duty materials to create a rugged and versatile clamping system. We combined ACME threaded screws and nuts with sprockets and a chain driven vise to give a smooth operating double screw action and amazing clamping power. We believe that you will find this to be the most effective face vise available today.

When we first started making workbenches we used the best hardware that we could find, and while it was quite good we found that there was certainly room for improvement. We have since designed hardware that allows a wide board to be clamped between the screws, and that does not rack when clamping outside the screws.

NOTE: This vise is designed to be installed on a 4" thick top. The hardware can be mounted on a thicker top by ensuring all measurements for the center lines of the clearance holes in the jaw and bench are taken from the bottom. If your bench is less than 4" thick you will require blocking and an apron to get the appropriate clamping effect.

Chain Drive Vise Installation Time: Up to 12 hours (including making your own Vise Jaw and Bench prep.)

Total Travel Distance: 8 inches

An Installation Kit is available through Lie-Nielsen Toolworks for \$45, returnable for credit.
This kit includes the following tools:

Drills	F
Taps	5/16"-18
Center Punches	3/8", 5/16"
Allen Wrenches	1/8", 1/4"
Hex Drivers	3/16", 1/4"

Please call 1-800-327-2520 or visit www.lie-nielsen.com for more information.

IMPORTANT

- Read these instructions thoroughly before cutting into your bench and starting the installation.
 - Do not proceed without the vise parts and hardware in your possession.
 - Always clean any rough edges or debris before proceeding to the next step.
 - Do not overtighten the bolts.

CHAIN DRIVE VISE PARTS LIST

PART #1
WASHER (8)



PART #9
CAP SCREWS (8)



PART #2
BEARING (4)



PART #10
FLAT HEAD SCREWS (2)



PART #3
BRONZE BUSHING (4)



PART #11
VISE STANDOFF (2)

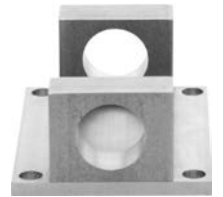

PART #4
SPROCKET (2)



PART #12
FLANGE (1)



PART #5
SPROCKET SET SCREW (4)
(2 PER SPROCKET)



PART #13
T-HANDLE & SCREW (1)



PART #6
KEY (2)



PART #14
CHAIN (1)



PART #7
JAM NUT (2)



PART #15
VISE DRIVE SCREW (1)



PART #8
LARGE STANDOFF NUT (2)



PART #16
VISE SCREW (1)



CHAIN DRIVE VISE EXPLODED DIAGRAM

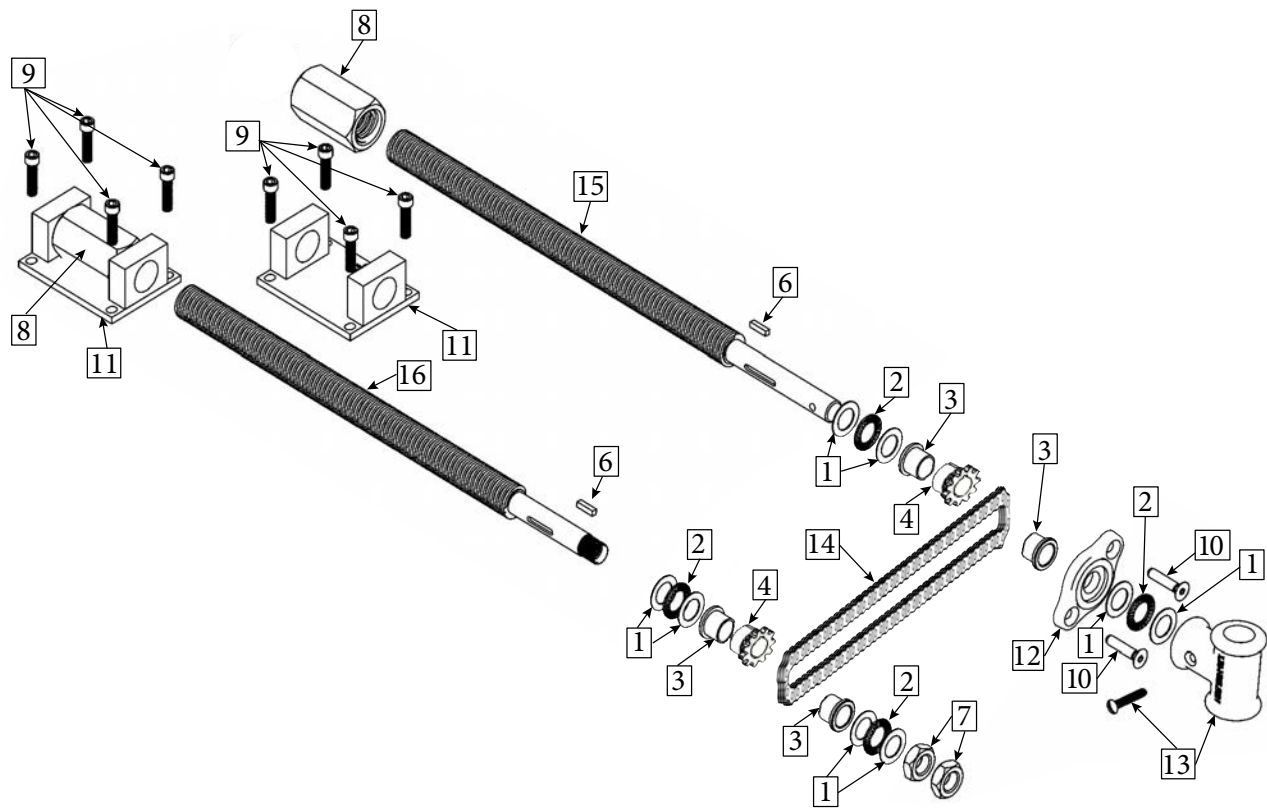

Part #	Part Name:
1	Washer
2	Bearing
3	Bronze Bushing
4	Sprocket
5	Set Screw (not shown)
6	Key
7	Jam Nut
8	Large Standoff Nut
9	Cap Screw
10	Flat Head Screw
11	Vise Standoff
12	Flange
13	T-Handle & Screw
14	Chain
15	Vise Drive Screw
16	Vise Screw

SPECIAL NOTES:

Your Chain Drive Vise Hardware is packaged fully assembled. You will need to disassemble the hardware before you begin the installation.

The Keys (Part#6) installed in the hardware may come loose during shipping. If you cannot find both Keys, please carefully search the package contents before calling our customer support line.

STEP 1: PREPARE YOUR BENCH TOP

Use Diagram 1A to make the measurements for your bench top.

To begin, determine where your first hole will be drilled on the face of your bench top.

Once you have marked the center of your first hole, use the measurements in Table 1A to determine the measurements for your next center mark. We recommend using a center punch to ensure the accuracy of your holes.

Next you will need to draw a center line mark off of your center marks from the face of your bench top to the back of your bench top. This will determine the center line for your standoffs and pockets.

***IMPORTANT:** The measurements in Diagram 1A are based off of a 4" thick solid Bench Top.

******The measurements in the Diagram 1A are the minimal measurements needed to ensure that you will have the proper amount of space required for your Chain Drive Vise Hardware to fit.

*******It is very important that the holes drilled through the face of your bench top, are square to the bottom of the bench top to ensure your Chain Drive Vise Hardware does not bind.

TABLE 1A: Center to center measurements between vise screw holes	
12" Chain	= 13-5/16"
18" Chain	= 19-5/16"
24" Chain	= 25-5/16"

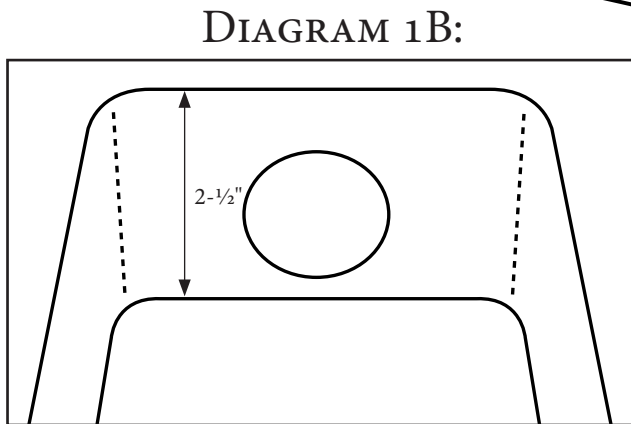
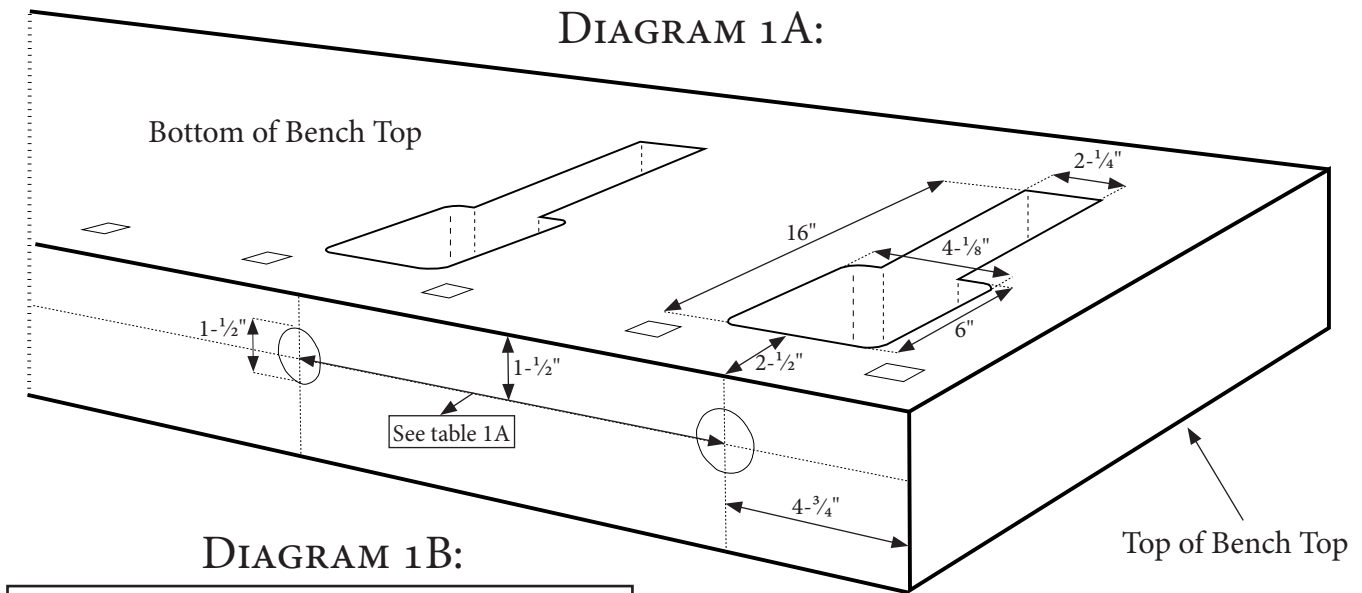

Diagram 1B shows the depth you need to make the pockets so the hardware fits properly. This view is looking down into the pockets, looking towards the holes in the front of the Bench Top.

STEP 2: PREPARE YOUR VISE JAW

TABLE 2A: Vise Jaw Half Dimensions (x2)

12" Chain = 22-13/16" x 4" x 1-3/8"

18" Chain = 28-13/16" x 4" x 1-3/8"

24" Chain = 34-13/16" x 4" x 1-3/8"

Length - Width - Thickness

Next, you will need to make the wood jaw for your vise. You will need to prepare it in two halves that will be glued together.

HALF NO. 1:

DIAGRAM 2A:

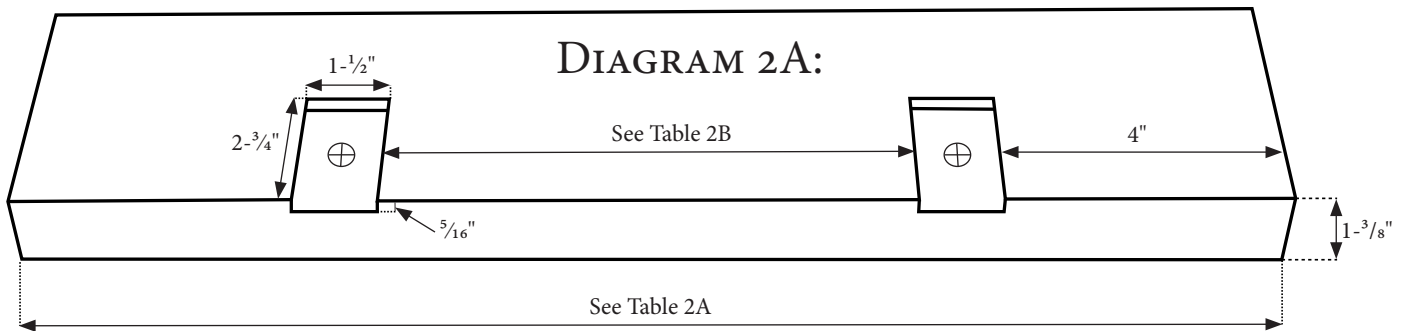

TABLE 2B: Vise Jaw Half No. 1 Dimensions

12" Chain = 11-13/16"

18" Chain = 17-13/16"

24" Chain = 23-13/16"

The conversions in Table 2B are the measurements from the inside edge to inside edge for the two pockets you will be making on Half No. 1.

HALF NO. 2:

DIAGRAM 2B:

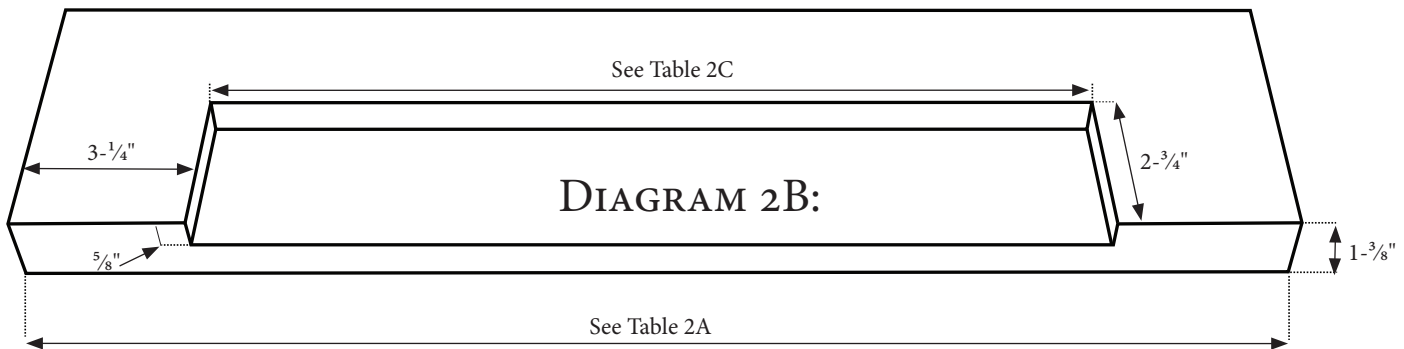

TABLE 2C: Vise Jaw Half No. 2 Dimensions

12" Chain = 16-5/16"

18" Chain = 22-5/16"

24" Chain = 28-5/16"

The conversions in Table 2C are the edge to edge measurements going left to right for the large pocket you will be making on Half No. 2.

Once you have finished preparing your vise jaw halves you will need to glue the two pieces together. Make sure that they align flush on the top side of the jaw halves. Be sure to use plenty of clamps and leave your vise jaw clamped together until the glue has fully dried. Next, after the vise jaw is glued and dried you will need to flatten the inside face of your vise jaw to ensure it fits flush to the face of your bench top.

MEASUREMENTS FOR THE LAYOUT OF VISE JAW HOLES

DIAGRAM 2C:

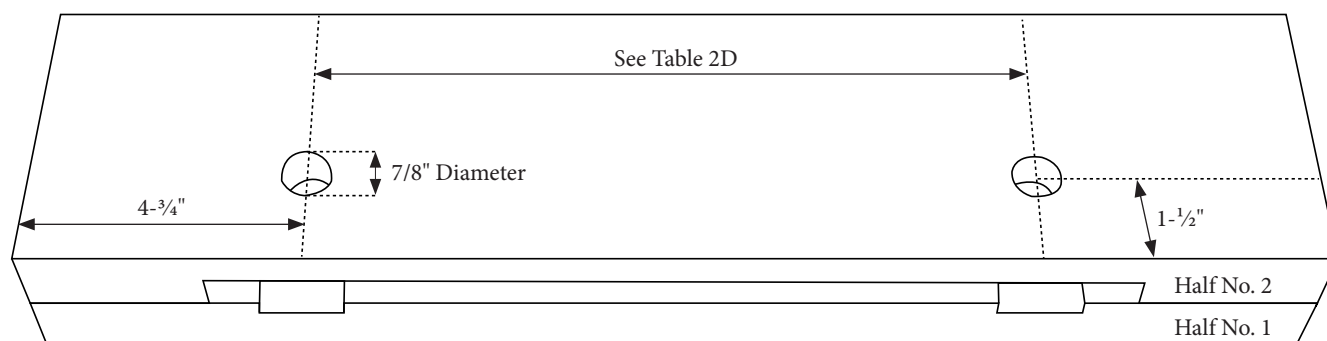
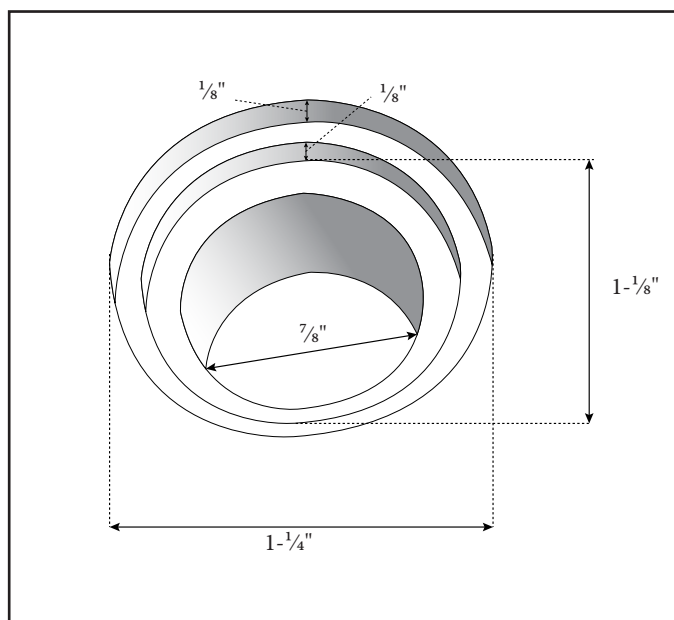

TABLE 2D: Vise Screw Holes: Center to Center Distance
12" Chain = 13-5/16"
18" Chain = 19-5/16"
24" Chain = 25-5/16"

Using a center punch and the measurements in Diagram 2C and Table 2D mark the center points of vise screw holes.

DIAGRAM 2D:



The final step in preparing the vise jaw is to drill and counterbore the holes you just marked. Do not drill all the way through the vise jaw until the counterbores have been drilled. The $\frac{7}{8}$ " hole should be the last step.

Use the specifications in Diagram 2D to make your counterbores. Forstner Bits are recommended if you plan to drill the holes. Be sure to drill the largest hole first, and work your way down to the smallest hole. You may also make a simple template and use an electric router to counterbore the holes.

Repeat steps on all the holes of your vise jaw, on both sides. **Do not to drill the $\frac{7}{8}$ " hole first.** This is to prevent the risk of tearout and keep your center mark.

STEP 3: INSTALL VISE JAW & VISE SCREW HARDWARE

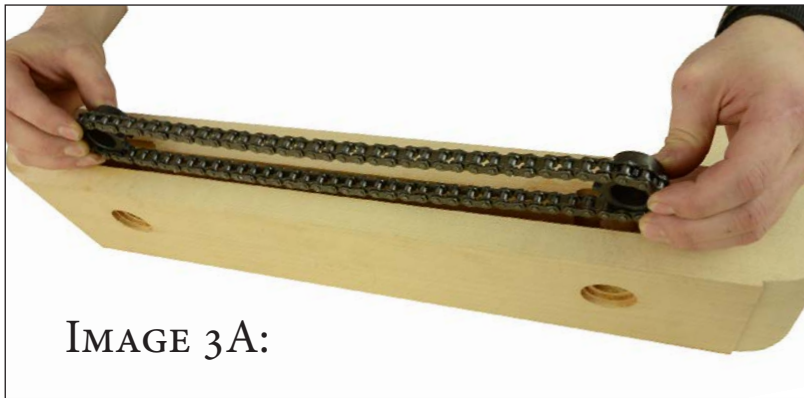

Assemble and install the Chain (Part #14) & Sprockets (Part #4) into your vise jaw as seen in image 3A.

*IMPORTANT: When installing the sprockets & chain into your vise jaw, make sure the slot for the Key (Part #6) on each sprocket is aligned to the 12 O'clock position to make installing the vise screws easier.

DIAGRAM 3A:

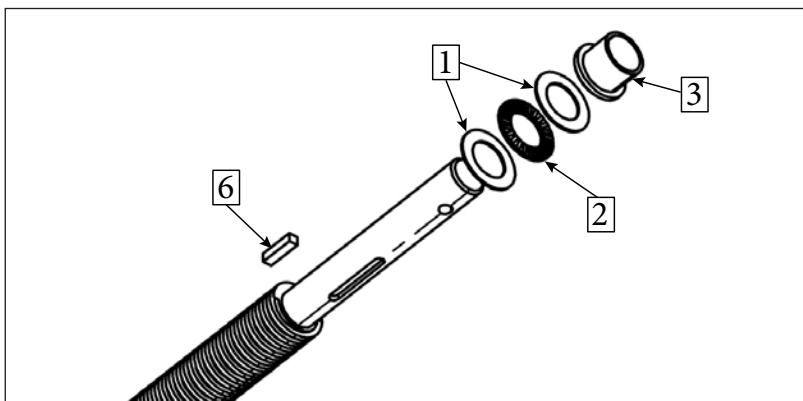

Before you insert the vise screws into your vise jaw, make sure you have installed the hardware as demonstrated in Diagram 3A. Lock these items into position by inserting the key into the groove of the vise screw. Make sure the hardware is seated fully snug against the threads on the vise screws.



Insert the vise screws into the back of your vise jaw as seen in Image 3B. Make sure the vise screw is seated firmly into your vise jaw before continuing.

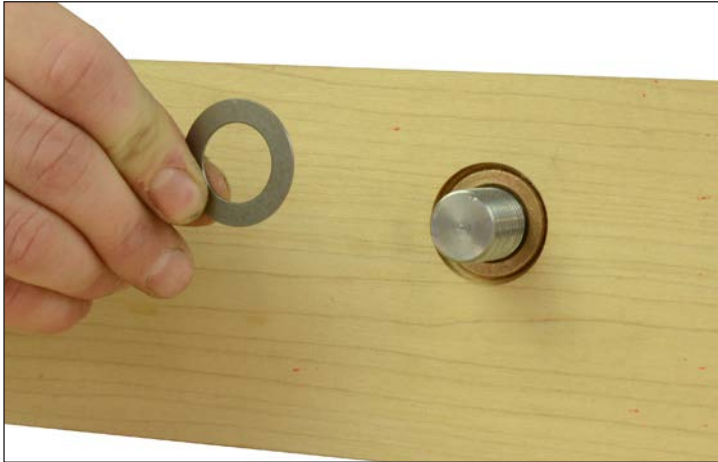

Turn your vise jaw around to install the remaining hardware. Install a Bronze Bushing (Part #3), followed by a Washer (Part #1), followed by a Bearing (Part #2), followed by another washer. Make sure these parts are seated firmly into your vise jaw.



Install the two Jam Nuts (Part #7) onto your Vise Screw (Part #16). The first jam nut should be snug against the washer but not too tight. Once the second jam nut is snug against the first jam nut, use two wrenches to tighten both jam nuts against each other to lock them into place.



Install the last Bronze Bushing (Part #3) on your vise drive screws. Make sure they are seated fully into your vise jaw holes.

***IMPORTANT:** Do not over tighten the jam nuts. Snug is plenty.

****When installing the bronze bushings we recommend using a flat tipped tools to ensure they are seated firmly into their counter bores. An allen wrench works well, one is included with your Installation Kit.**

STEP 4: INSTALL T-HANDLE ASSEMBLY



Install your Flange (Part #12), followed by a Washer (Part #1), Followed by a Bearing (Part #2), and followed by another washer.



Next using a large flat tip screwdriver, ensure your Sprockets (Part #4) are fully seated into the holes of your vise jaw assembly.

Once your Sprockets are set, tighten the 2 Set Screws (Part#5) on each sprocket.



To install your Flat Head Screws (Part #10), you will need to use a 5/16" center punch and a 5/16" tap.

First ensure the flange is level, then use the punch to make the center marks.

Next using the F sized bit from your Installation Kit to drill a hole into your vise jaw all the way into the gap of your vise jaw.

Use the Tap to make the threads for the screws.

Use a 3/16" Hex Driver from the Installation Kit to thread the screws into the Flange.

***IMPORTANT:** Do not over tighten the screws on your T-handle or your flange and set screws.

******When tapping your vise jaw for the flange screws, we recommend using a 1/4" extension.

STEP 5: MOUNTING STANDOFFS

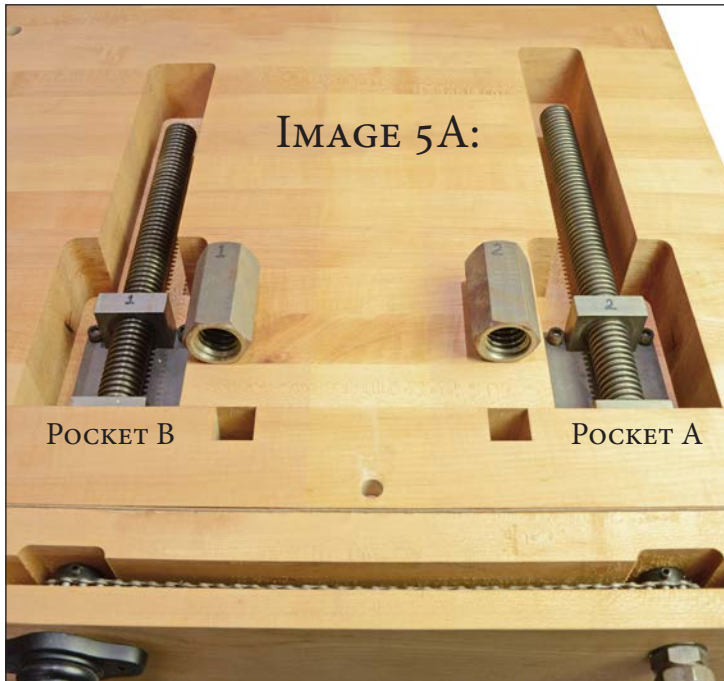

Image 5A shows 2 pockets. Pockets A & B.

Pocket A contains your Vise Screw (Part #16) You will be securing the Standoff (Part #11) in Pocket A to the bench top first.

Pocket B will contain your Vise Drive Screw (Part #15). Leave the standoff in this pocket loose.

See the formation of the standoffs in Image 5A before you begin this step.

Install the vise jaw assembly into the bench top as seen in Image 5A.

Use a large vise clamp to secure the vise jaw assembly to your bench top.

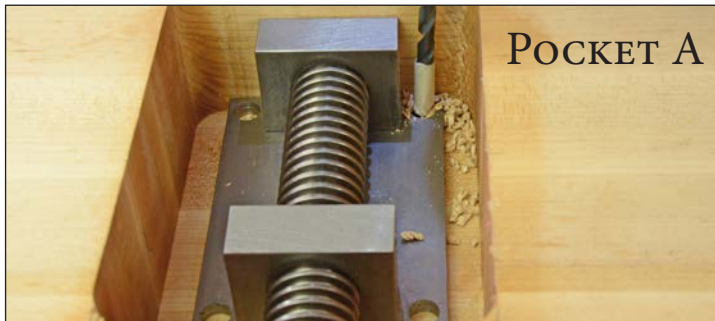

In Pocket A, slide the standoff firmly against the edge of the pocket closest to your vise jaw.

Use a 3/8" center punch to mark the four screw holes on your standoff. Using a 1/4" drill bit, drill a hole 1-1/4" deep into your bench top.



Install four standoff screws using a 1/4" hex driver from your Installation Kit.

***IMPORTANT:** The screws for the standoffs are designed so you do not need to tap the hole you drilled during installation.

****Do not over tighten the screws on your standoffs.**

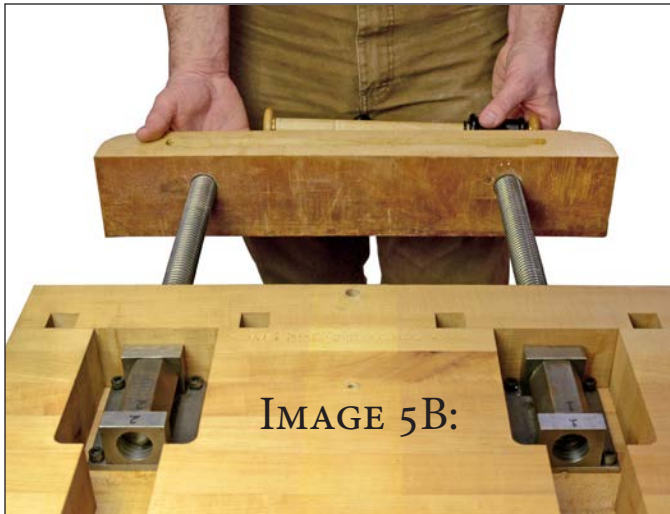

Remove the large vise clamp and retract your vise jaw assembly until the vise screws are just inside the bench top as seen in image 5B.

Install the Large Standoff Nuts (Part #8) into your Standoffs (Part #11) as seen in image 5B.

Begin to thread your vise jaw assembly into the standoffs. Stop periodically and check the measurements from the inside edge of your vise jaw assembly to the outside edge of your bench top to ensure the Chain Drive Vise is threading evenly into the standoffs.

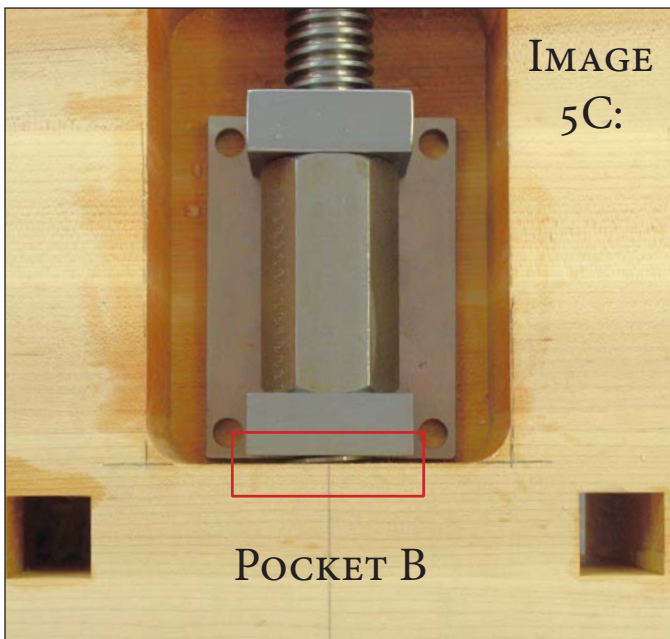

Thread the vise jaw assembly until it is flush against the face of your bench top.

You should be left with a slight gap between the standoff and the edge of Pocket B as seen in image 5C.

***IMPORTANT:** If the gap is too large or too small, you will need to retract the vise jaw assembly and rotate the large standoff nut in this pocket. This will adjust the timing of your Chain Drive Vise. This step may be repeated several times to get the desired result.

Once you have the standoff in the desired position, fasten your standoff using the previous instructions on Pg. 12.

***IMPORTANT:** When threading the vise jaw assembly into the standoffs and large standoff nuts for the first time, make sure the standoff that is not secured yet is as close to the edge of the pocket nearest your jaw vise assembly to achieve the proper timing of the Chain Drive Vise.

******Once the vise hardware is installed, be careful not to back the vise screws completely out of the standoff nuts. The total travel distance for the vise jaw is approximately 8 inches.

ENJOY!



We hope that you enjoy your new Chain Drive Vise!

If you have any questions, suggestions, or feedback, please contact Lie-Nielsen Toolworks at 1-800-327-2520 or email toolworks@lie-nielsen.com.

We also offer bench dogs, vise handles, and holdfasts. For details or to place an order, please visit the Workbench Hardware section of our website at www.lie-nielsen.com.



WOODEN
BENCH DOGS



METAL
BENCH DOGS



WOODEN VISE HANDLES



HOLDFAST